

## Specification

---

Model No.: APA102H5050

Product: 5V SOP6 0.3W Intelligent led

Document No.: SPC-TOP-C/230021

Issue Date :18-04-2023

Version: C-23



Greeled Approval		Customer Approval	
Aduit	Confirmation	Aprroval	Audit
Mr Chiang	Ms Lee		
Date:		<input type="checkbox"/> Qualified	<input type="checkbox"/> Disqualified
Reason:			

## 1.Feature:

- RGB Chips and IC are integrated in one SMD5050 package as one pixel.Built in various function circuit units.
- Clock and data dual signal SPI Protocol,It is compatible with APA102
- The PWM scanning frequency up to 26KHz+.
- It can support data transmission rate at max 40Mhz Clock frequency(20Mbps)
- Double dimming function,32bit data frame, 5bit for dimming whole brightness, 3\*8bit 256 grayscale to fixed color.
- Input voltage DC5V,Default output current 17mA Per color.
- No signal input when power on,No light.
- Don't need capacitor in circuit.

## 2.Application:

LED Billboard,LED Screen,Device etc.

## 3.Package dimension:

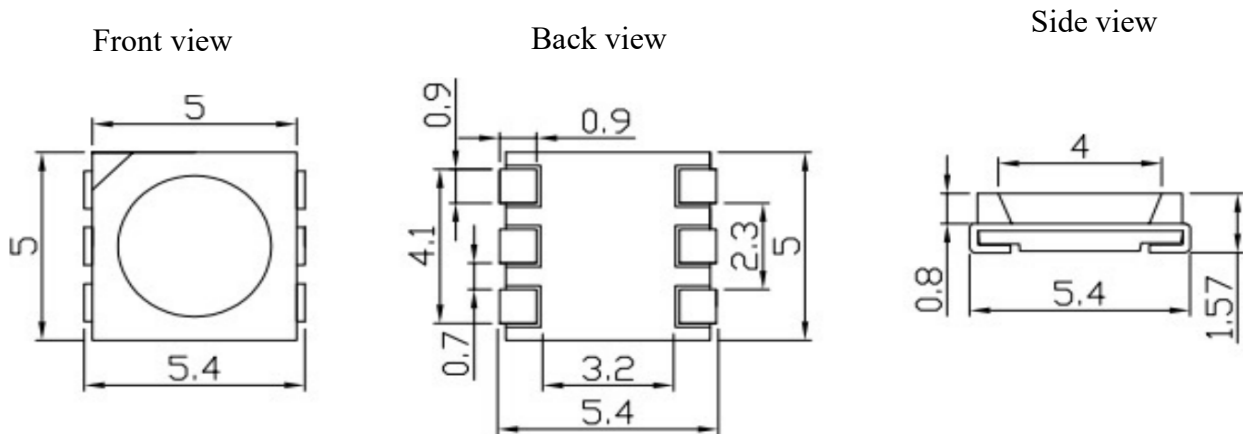

Remarks: All dimensions are marked in millimeters and the tolerance is  $\pm 0.15$  mm, unless otherwise specified.

#### 4.Pin diagram and function description:

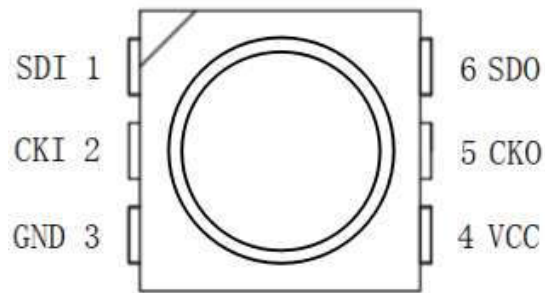

No.	Symbol	Function description
1	SDI	Data signal input
2	CKI	Clock signal input
3	GND	Ground
4	VCC	Power supply
5	CKO	Clock signal output
6	SDO	Forwarding data signal out

#### 5.RGB chip characteristic parameter Ta=25℃:

Color	Wavelength(nm)	Light Intensity ( mcd )	Lumen ( LM )
Red	620-630	480-800	1.5-2.5
Green	520-535	1200-1500	4.0-5.0
Blue	460-475	300-600	1.0-2.0

#### 6.Electrical parameters (limit parameters, unless otherwise specified, Ta=25℃):

Parameter	Symbol	Range	Unit
Voltage	VDD	-0.5~+5.5	V
Logic input voltage	VI	GND-0.3~VDD+0.3	V
Working temperature	Topt	-40~+85	℃
Storage temperature	Tstg	-50~+85	℃
ESD pressure ( Device mode )	VESD	200	V
ESD pressure ( body mode )	VESD	2000	V

## 7. Electrical characteristics (if no special instructions, VDD=5V, Ta=25°C):

Parameter	Symbol	Min	Typical	Max	Unit	Test Conditions
The chip supply Voltage	VDD	-	5.0	5.3	V	-
R/G/B port output current	IOUT	-	17	20	mA	-
Clock high level width	TCLKH	-	-	>30	ns	-
Clock low level width	TCLKL	-	-	>30	ns	-
Data creation time	Tsetup	-	-	>10	ns	-
PWM output frequency	Fpwm	-	26	28	KHz	-
Static current	IDD	-	1	-	uA	-
Data rate	bps_max	-	-	20	Mbps	-
High Level	VIH	3.5	-	5.3	V	-
Low Level	VIL	-0.3	-	1.5	V	-

## 8. Block Diagram

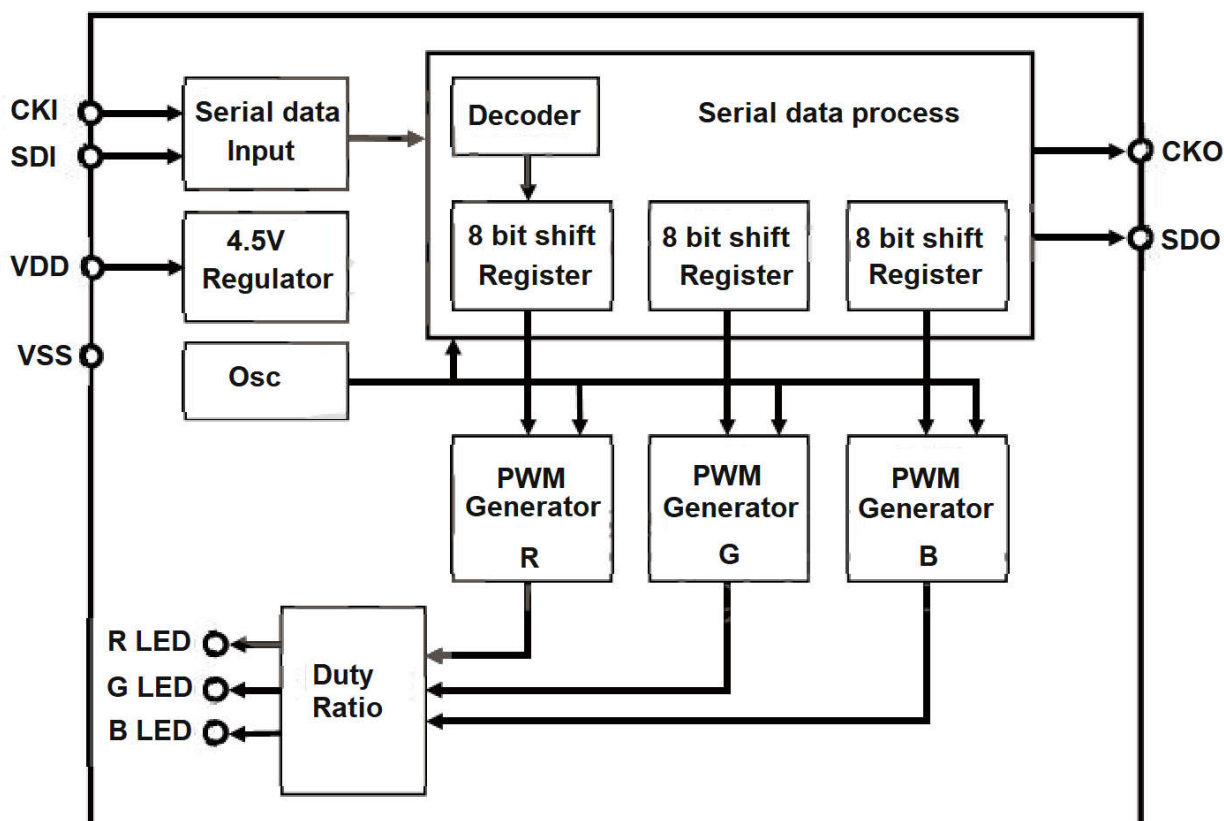

## 9.Data communication protocol description (Dual signal SPI Protocol):

(1) The data format as below

SDI	32 bit 0	LED 1	LED 2	LED 3	-----	LED N	32 bit 1
	Start Frame	Data Frame	Data Frame	Data Frame		Data Frame	End Frame

Start Frame32bit	0000 0000	0000 0000	0000 0000	0000 0000
	8bit	8bit	8bit	8bit

Data Frame	111	Brightness adjustment	BLUE	GREEN	RED
	3bit	5bit	8bit	8bit	8bit

End Frame	1111 1111	1111 1111	1111 1111	1111 1111
	8bit	8bit	8bit	8bit

Each updated data format include 32 bit 0 start frame , many32 bit data frame and 32bit end frame.Min 32 bit 0 are required for it to initiate a new data update, and increasing the number of zeroes does not affect. The Data frame consists of brightness adjustment bit and RGB bit, and it is identified by the first one bit following the start frame.The LED output color is updated immediately after the first valid data frame, and the most significant bit of the data frame has to be "1", as it is used to identify the start of the frame. And the next two bit serve no function but recommend to set them to "1". Brightness adjustment bit: 5 bit (32 level) brightness setting, while controlling R,G,B three-color constant current output value, if set the brightness adjustment bit for the 10000( 16/31 ) is the output current is half again the original PWM settings. See diagram below:

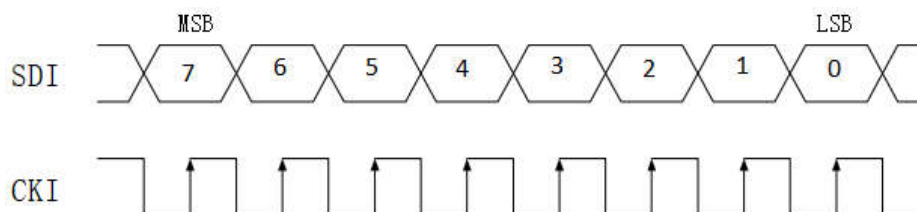

Whole brightness adjustment (5bit) MSB-----LSB	Percentage of driving Current
00000	0/31
00001	1/31
-----	-----
01010	6/31
01011	7/31
-----	-----
10100	20/31
-----	-----
11111	31/31

**(2) 8bit Per color, R/G/B 256Grayscale setting**

R/G/B grayscale setting (8bit) MSB-----LSB	Duty Ratio Brightness level
00000000	0/255
00000001	1/255
-----	-----
01010000	80/255
01010001	81/255
-----	-----
10100000	160/255
-----	-----
11111111	255/255

**(3) Color bit sending sequence**

B7	B6	B5	B4	B3	B2	B0	G7	G6	G5	G4
G3	G2	G1	G0	R7	R6	R4	R3	R2	R1	R0

**Note: The high bit is sent first, and the data is sent in the order of (B7 → B6 →.....R0)**

**(4) Calculate refresh rate**

Refresh rate=1/((64+(32\*Pixel Qty))\*T-CKI ) (unit frame/second)

T-CKI means Clock cycle

For example: 1024 Pixel, CKI frequency is 1Mhz,

T-CKI is 1/1MHz = 1us, so the refresh rate = 1/ [(64+ (32 x 1024)) x 0.000001s] = 30.458 fps.

It means refresh rate about 30framesin a second

**(5) Calculate the number of pixel**

Number of LED pixel = (F-CKI / refresh rate - 64 ) / 32;

F-CKI means Clock frequency

Do increase the number of cascaded pixel, it needs to increase the CKI frequency or decrease the refresh rate.

**10. Typical application circuit:**

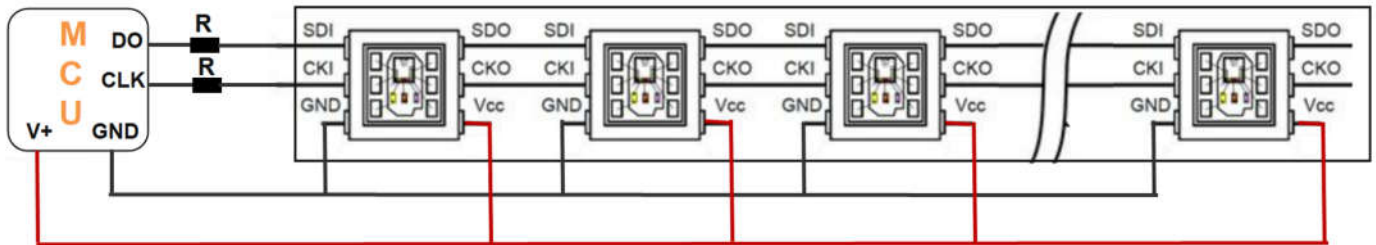

The signal input and output terminals of the product need to be connected in series with a protective resistor R when necessary . The value of the protective resistor R depends on the number of cascaded led. The more the number of cascades, the smaller the R. Generally, The value between 27-51 ohms is recommended. The recommended value is around 33 ohms.

# 11. Typical optical characteristic curve:

Welding temperature VS Forward current

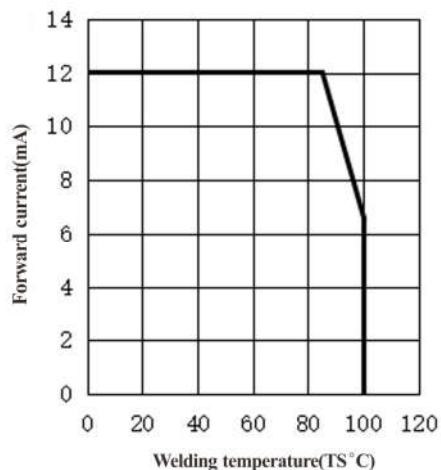

Forward current VS Relative light intensity

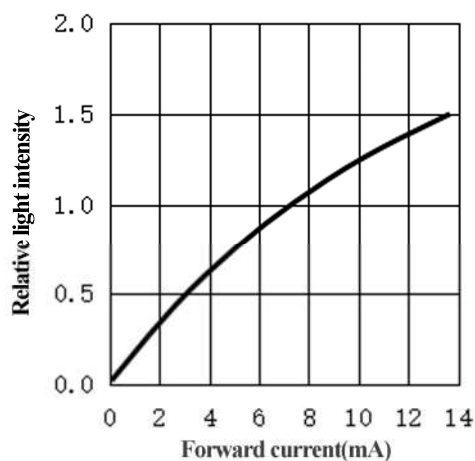

Forward voltage VS Forward current

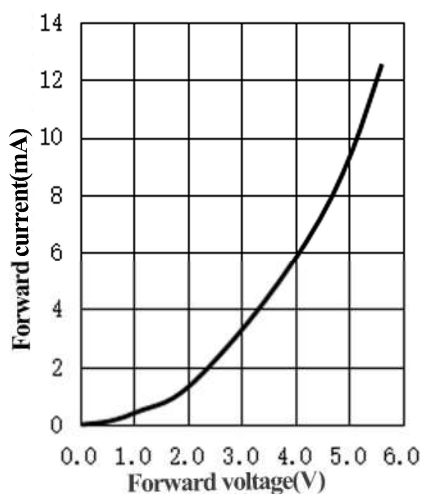

Ambient temperature VS Relative light intensity

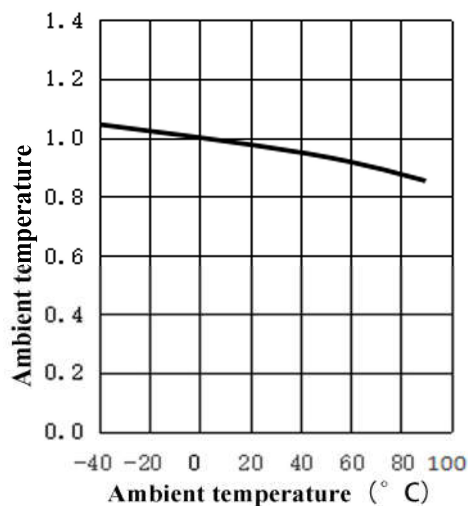

Relative spectral distribution chart

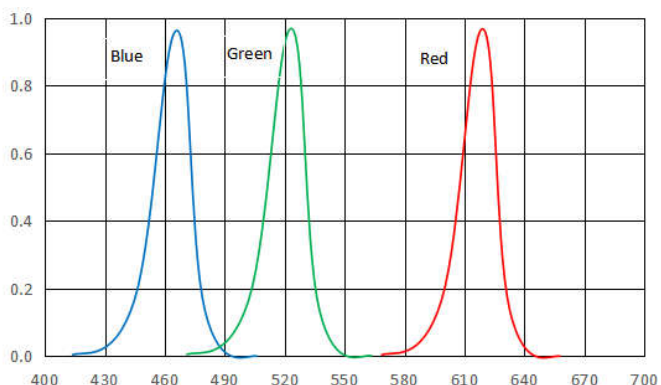

Relative spectral distribution chart

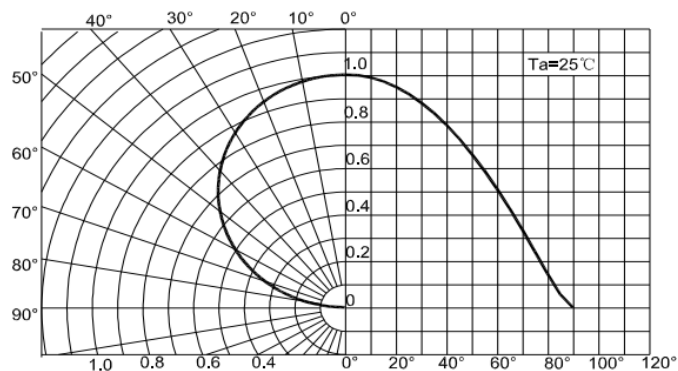



## 12.Packing specifications:

Reel size:

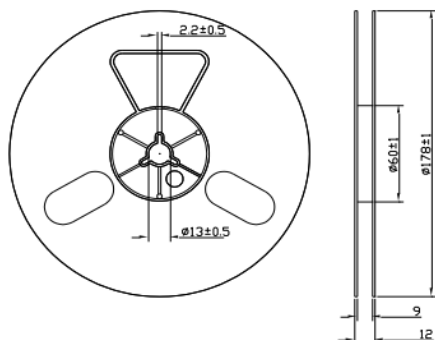

Carrier tape specifications (unit: mm)

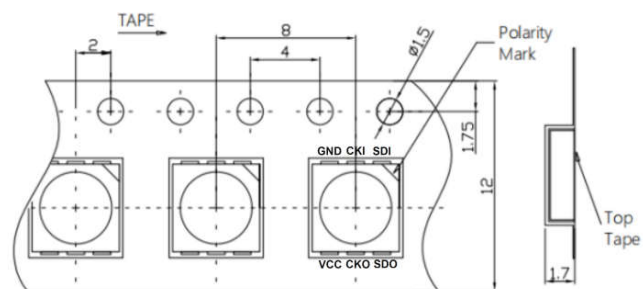

Moisture-proof bag packaging:

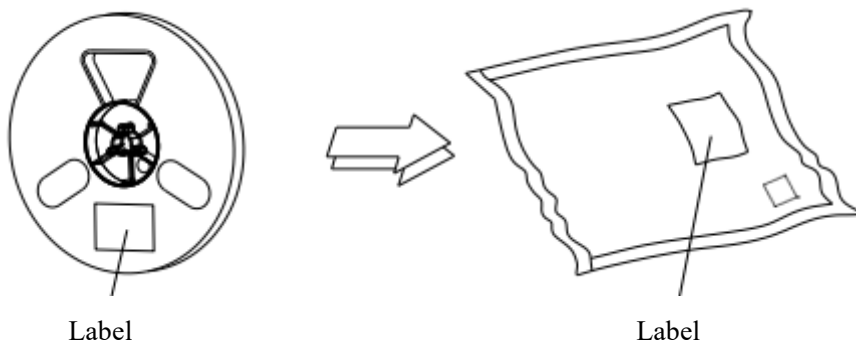

Note: The marked tolerance is ±0.1mm, unit: mm

Model No.	Description	Qty/bag	Bag/Ctn
APA102H5050	SMD5050,6feet,RGB,8bit	1000pcs	50bag

## GREELED ELECTRONIC LTD

Add: 2F,1st Building logistic park,shiyang town,shenzhen city

E-mail:sales@gree-leds.com Skype:greeledelectronic